

GRUNDIG

TK 148 Automatic

Service data

Service Information

Numbers in () in the text refer to numbers in the spare parts list for the TK148. Hard or metallic/magnetic objects should not be brought into contact with the heads as this may cause damage.

Fig 1 Removing Top Cover and Housing (87)

Remove the five screws (91) the handle (102) and the handle securing screw (94). Pull off the speed change lever (104), the record button (99), the function lever (97) and the knobs (101), taking care not to lose the felt pads. Pull off the function lever (96) and the top cover (87) can be removed.

Fig 2 Removing Base (92)

Removing the four screws (a) pull the mains cable through the cable compartment. Remove the base (92) letting the cable slide through the outlet hole.

Fig 7 Amplifier Printed Circuit Board (111) - Solder Side

After removing the housing (87) (as in Fig 1) undo the two screws (b) and pull the screening plate from it's key way.

Fig 5/7 Amplifier Printed Circuit Board (110) - Component Side

Dismantle both the top cover screen and the base. Gently pull out the control printed circuit board (145) after bending away location flaps on top of chassis. Remove the screw (c), and pull the printed circuit board (110) down and out.

NOTE:- The function selection lever should be in the "START" position

Fig 1/7 Servicing the Heads and Sound Channel

Remove the head cover (90), and clean the heads, tape guides and sound channel with methylated spirits.

Fig 7 Changing and Adjusting Heads

(for securing screws, see illustration). Adjustments are made using Grundig Alignment Tape 464. The vertical height of the record/playback head is made with screw (h), azimuth adjustment with screw (n).

Fig 5/6 Changing the Belts

Fully dismantle the machine, remove the screws (d), and take the bearing (49) off the flywheel spindle. Lift the belt out and over the spindle (as in fig 6). The belt (31) can now be pulled out.

Fig 3/4 Clutch Torque

The illustration shows the torque measured on the clutches.

Fig 7 Tape Drive

With the pressure band removed the tape must travel over the capstan spindle without looping. Adjust after loosening screws (e).

Fig 3/7 Pressure Roller

In the "PAUSE" position the pressure roller must be parallel with the capstan spindle. In the "START" position the pressure roller must take from 3-6 revolutions to travel from the top to the bottom position. Adjust with adjustment key 5999-035 after loosening screw (c). The pressure of the pressure roller on the capstan spindle in the "START" position should be 700gr + 10%, adjust with screw (g).

Fig 5 Contact Sets a1 and tt1

Pressing the record button in the "automatic" mode should not move contact "a1", and with "Trick" depressed, the contact tt1 must move 0.2mm to make.

Fig 5 The end of the tape stop is so adjusted that in the "STOP", "PAUSE", and in the rest position between "START" and fast forward wind the nose of the switch lever has a clearance of 0.3-0.5mm from the armature piece.

Correct after loosening the securing screw (f).

Bias Setting (need only be carried out if heads are changed)

Switch the machine to "RECORD", "MANUAL", "PAUSE" and with a capacitive voltage divider (i.e. VST24) connected to test point ∇ (tracks 1-2) or ∇ (tracks 3-4) on the track switching printed circuit board T. Adjust the bias voltage with C305 according to the colour coding of the head :-

Red 32V - White 36V - Black 40V - Yellow 44V

Heads which have two colour codes should be adjusted in the "arithmetical centre" i.e. Black/yellow = 42V (When the "TRICK" button is depressed the bias voltage should drop by 2.5V).

The erase voltage measured at ∇ or ∇ should be at least 15V.

The bias/erase frequency (measured via FM1) should lie between 62 and 76kHz. (When the "TRICK" button is depressed the frequency should fall by 15%).

Measurements Using Grundig Alignment Tape 9 (Type 46B) at 9 cm/s (3 $\frac{3}{4}$ i.p.s.)

The output of the 333Hz section of the tape measured at pins 3/2 of the "radio" socket must be 500mV from each track.

The output at other frequencies must lie within the following tolerance field (to DIN 45 511). If the deviation at 12.5kHz is excessive the head alignment should be checked.

Recording and Playback

Input via 470k Ω in parallel with 150pF to pins 1/2 of the radio socket.

Full Recording Level

Set the machine to Record, Automatic, 9.5 cm/s (3 $\frac{3}{4}$ i.p.s.), 333Hz, Vin - 200mV.

The playback voltage under these conditions should be at least 800mV, with a distortion factor k_2 of 4-5%. The voltage measured at ∇ should be 4V \pm 1.5dB, adjustable with R113 whilst making a new recording.

When these conditions are fulfilled, the recording level indicator can be checked. The lamp under the red field must only just light. Adjust with R509.

Frequency Response at 9.5 cm/s (3 $\frac{3}{4}$ i.p.s.) and 4.75 cm/s (1 $\frac{7}{8}$ i.p.s.)

(Machine switched to Manual)

Record a test tape at each speed with an input of 20mV at all frequencies. During playback the levels should lie within the following tolerance fields. If there should be any loss at 12.5kHz the HF bias point should be changed slightly

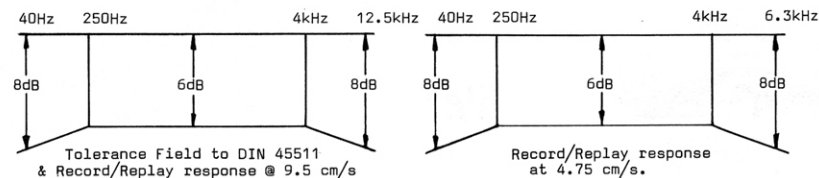
Automatic Working Point

Switch machine to "RECORD", "AUTOMATIC", "PAUSE". Place a short across resistors R104-R105, and connect a DC voltmeter to points ∇ ∇ . Set R108 for a reading of 0.8V.

- T 203 AD 161 9654-195
- T 204 9654-196
- T 203 AD 157 9654-189
- T 204 AD 158
- T 101 9654-146
- T 2 BC 239 C
- T 1 9654-146
- T 4 BC 237 B
- T 5 BC 237 B
- T 102 BC 237 A/B
- T 301 BC 337 167/25
- T 302 BC 337 167/25
- T 401 BC 237 B
- T 501 BC 237 B
- T 502 BC 237 B
- T 503 BC 238 C
- T 504 BC 238 C
- D 101 9654-093
- D 102 9654-093
- D 103 9654-093
- D 201 9654-188
- D 401 10 473
- D 501 10 473
- D 502 10 473
- D 503 10 474

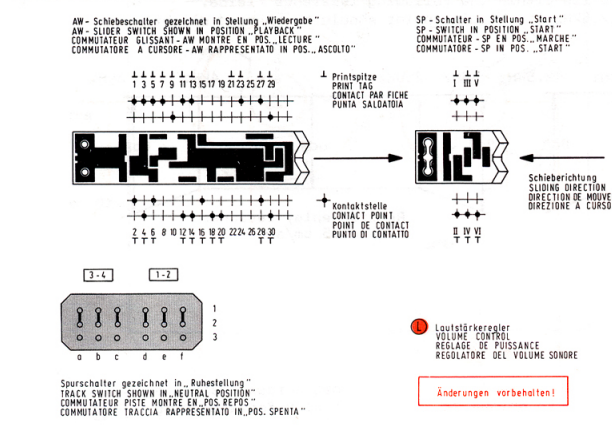
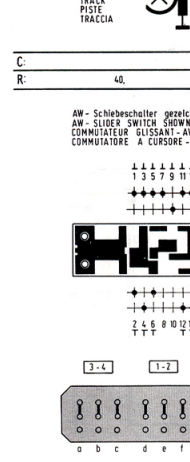
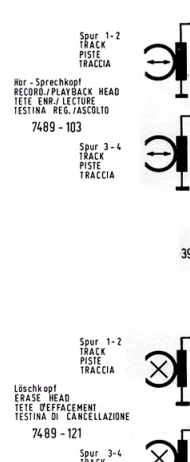
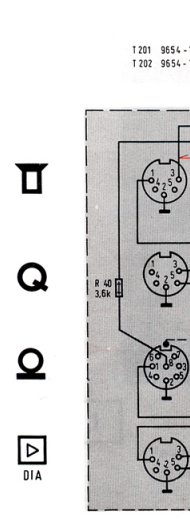

| | | | | | |
|---|-----|-----|------|------|---|
| Betriebs-/Position OPERATING POSITION POSITION DI SERVIZIO | a 1 | 111 | SP 1 | SP 2 | m |
| Aufnahme-Wählschalter RECORDING SELECTOR SELECTEUR D'ENREGISTREMENT COMMUTATORE SELETTORO DI REGISTRAZIONE | | | | | |
| Betriebs-/Pause/Start OPERATING/PAUSE/START SELECTEUR DE FONCTION-STOP/MARCHE COMMUTATORE DELLA POSIZIONE DI SERVIZIO-PAUSA/START | | | | | |
| Bandendabschaltung TAPE END SWITCH ARREI AUTOMATICO REGOLAZIONE DI FINE NASTRO | | | | | |
| Wird betätigt IS OPERATED ESTI OPERE VIENE COMANDATO | | | | | |

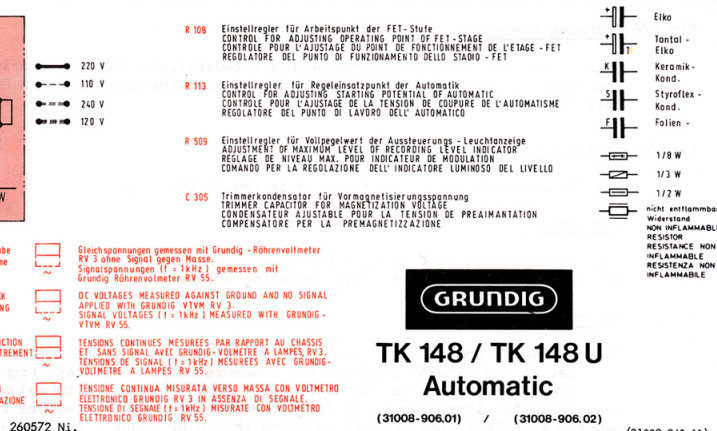
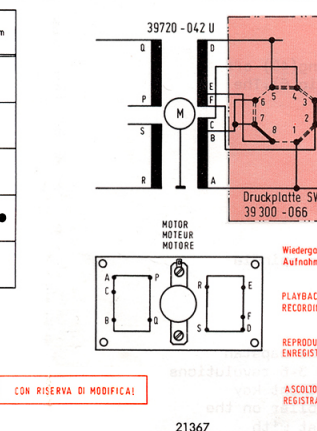

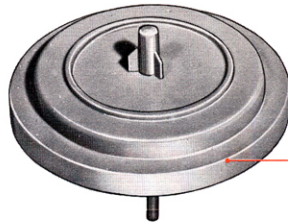
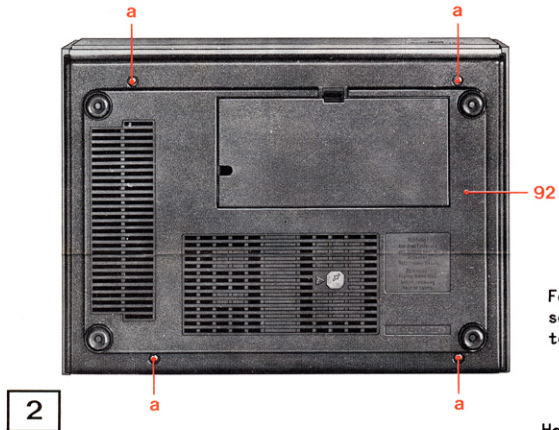
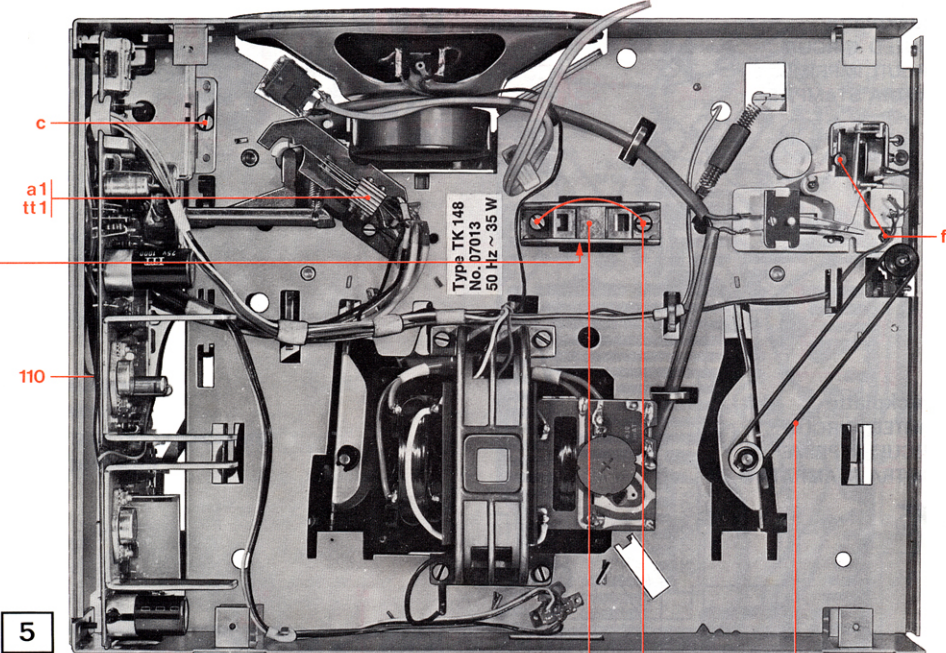
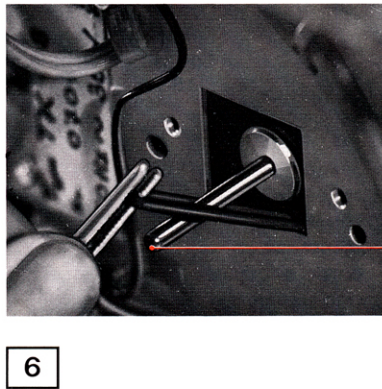
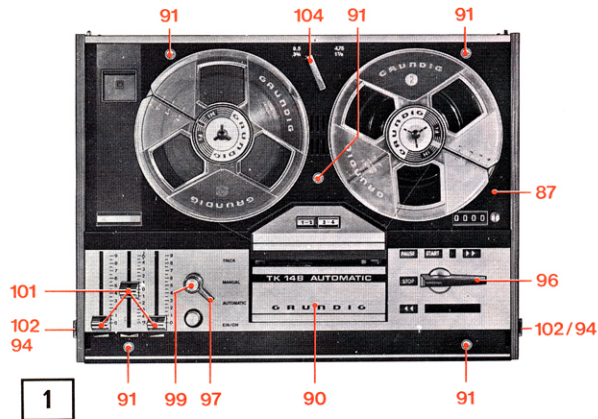

Felt pads for setting the tape tension

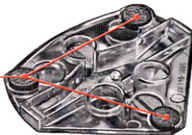

Height correction washer (9604-664)

only on right clutch

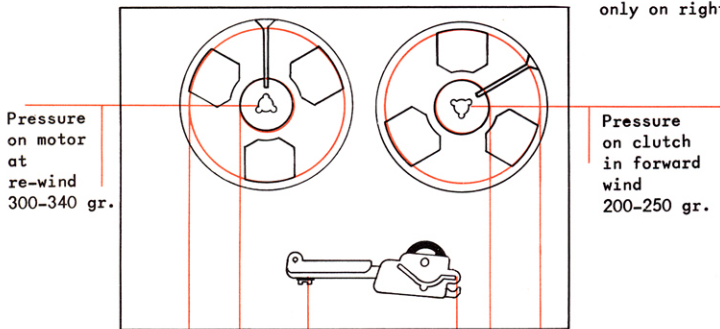

3

12 gr. at start 45 gr. at start

25 gr. at start 12 gr. at start

700 gr. + 10%

Spring contact point for 60 and 50 Hz

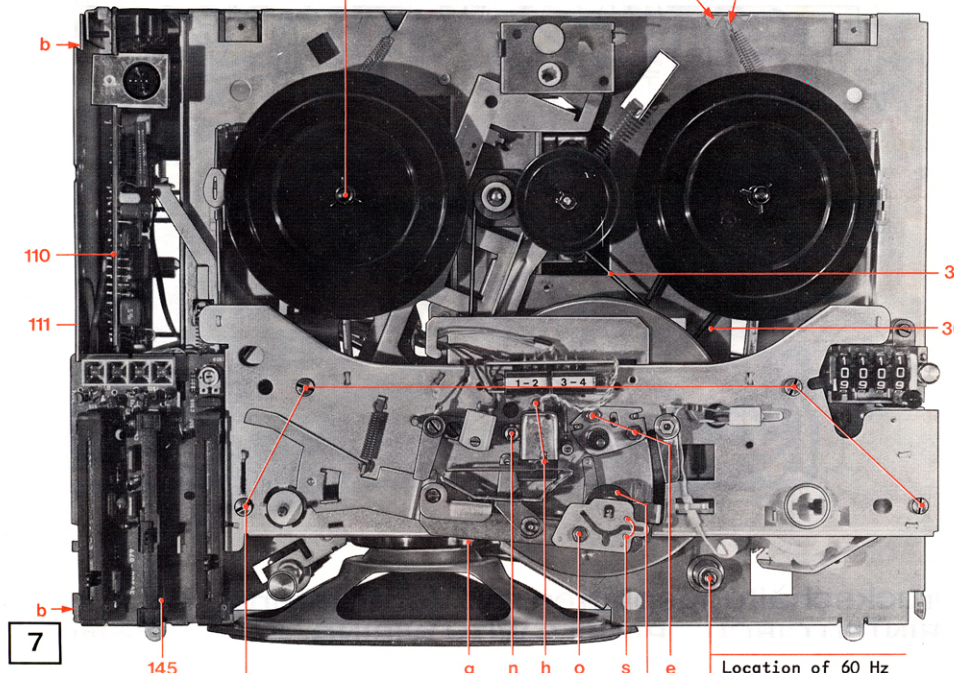

Location of 60 Hz conversion for U models

NOTE! Care must be taken when removing the four screws, as many moving parts pivot on the chassis plate.

PRINTED CIRCUIT PANELS WITH WIRING

Druckplatte
PRINTED CIRCUIT
CIRCUIT IMPRIME
PIASTRA STAMPATA

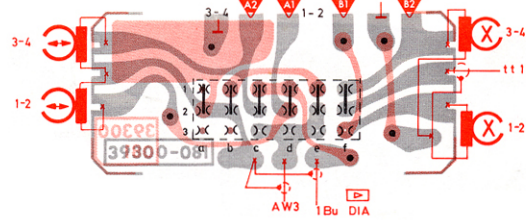

Druckplatte
PRINTED CIRCUIT
CIRCUIT IMPRIME
PIASTRA STAMPATA

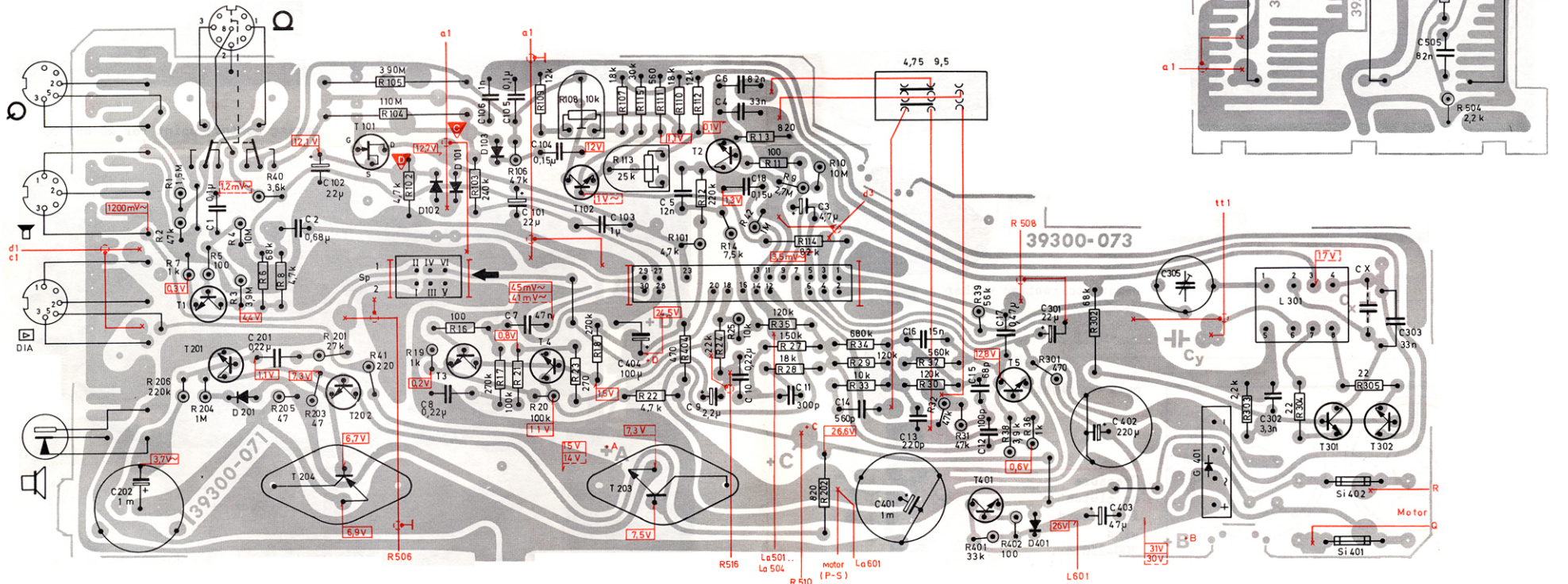

Druckplatte
PRINTED CIRCUIT
CIRCUIT IMPRIME
PIASTRA STAMPATA

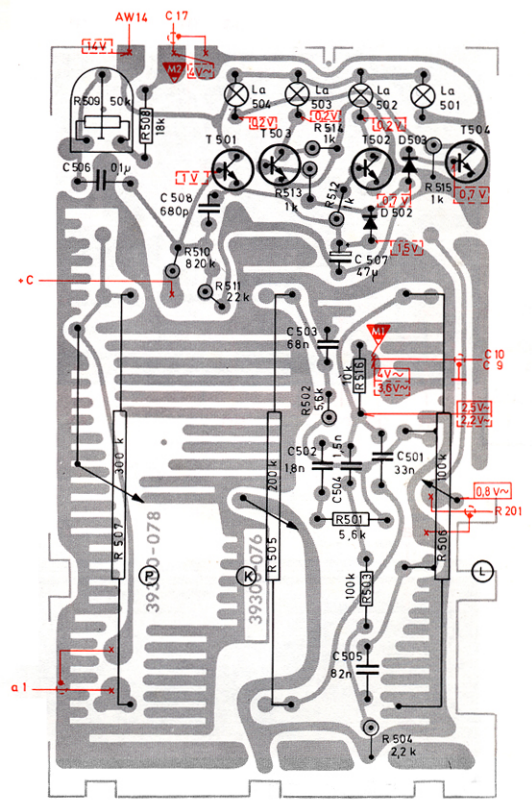

Lötseite
SOLDER SIDE
COTE DES SOUDURES
LATO SALDATURE

Bestückungsseite
COMPONENT SIDE
VUE DU COTE DES COMPOSANTS
LATO COMPONENTI